

Quest Technical Solutions
4110 Mourning Dove Court
Melbourne FL 32934
321 757-8483
website: www.qtsusa.com
email: sales@qtsusa.com

Automation Network X-Change

AN-X-GENI Module

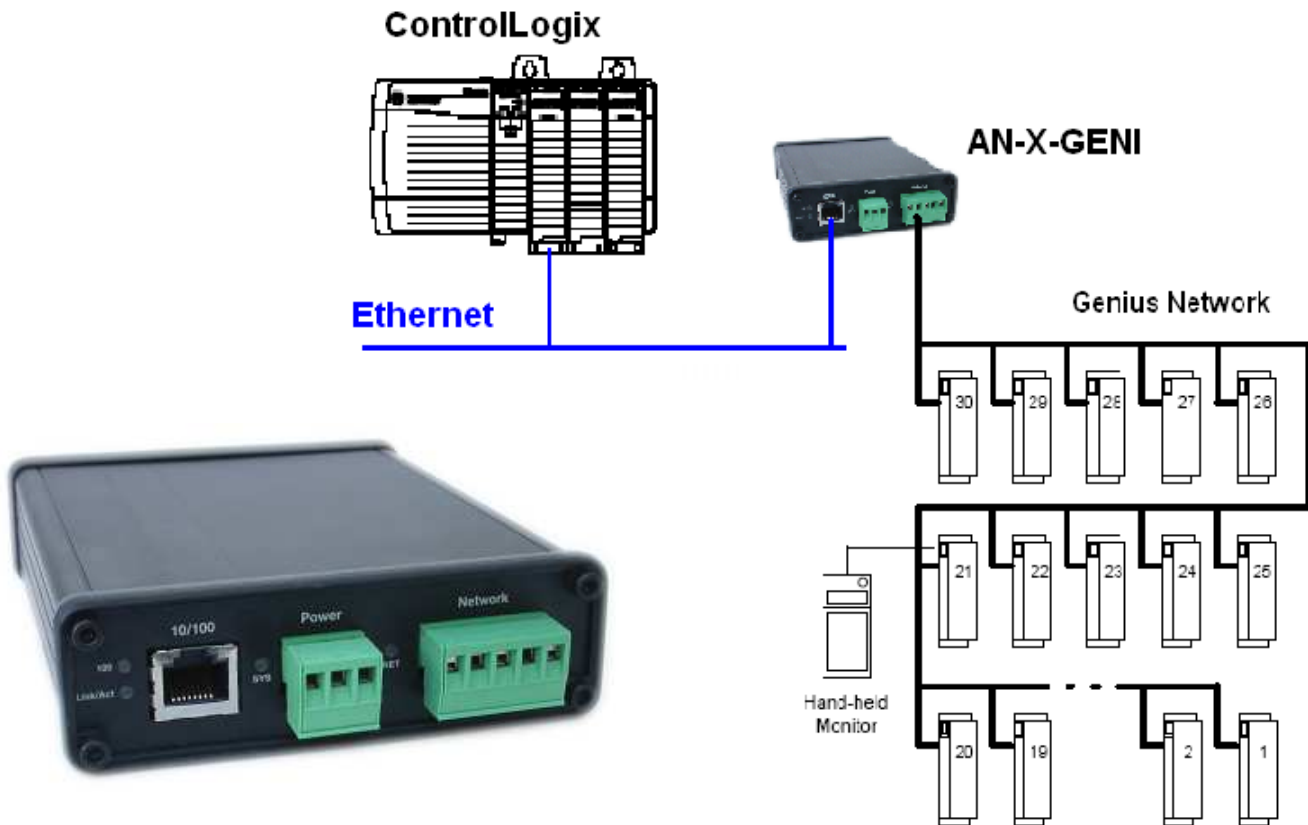

The AN-X-GENI module acts as a master on a Genius network. A ControlLogix processor can exchange scheduled data with the AN-X module to read Genius inputs and write Genius outputs.

The AN-X-GENI module:

- supports all Genius baud rates
- can be configured for any valid Genius serial bus address (SBA)
- scans up to 30 Genius blocks
- supports standard Genius I/O blocks, field control I/O, and global data to and from other processors
- supports autoconfiguration from an online Genius network. Can also be configured manually
- supports scheduled connections with a ControlLogix processor over Ethernet. There can be up to 15 connections (up to 250 16-bit words in/248 words out per connection), with RPIs from 5 ms to 750 ms.



- creates tags that can be imported into RSLogix 5000
- supports “ghost mode”. AN-X can monitor inputs and outputs on an existing Genius network and send the data to a ControlLogix
- is field upgradeable. The AN-X operating system and firmware can be upgraded over Ethernet

Web Access

AN-X acts as a web server. Any web browser can connect to AN-X to perform configuration and to monitor the AN-X module and Genius faults.

Specifications

- Power requirements: 12 - 24 VDC, 3 watts typical
- Dimensions: 107 mm X 126 mm x 34 mm (4.18" x 4.97" x 1.33"), not including connectors
- Desktop use or DIN mountable

The AN-X Product Family

Automation Network X-change (AN-X) is a product family designed by Quest Technical Solutions as a flexible platform for connecting to and monitoring automation networks.

A computer or other device (PLC, etc.) connects to AN-X via Ethernet, using one of a number of supported protocols. QTS is continually adding support for other networks. Contact us for information on the availability of an AN-X module for your network.

About QTS

Quest Technical Solutions is a provider of industrial communication hardware and software. Quest employees have many years combined experience in developing industrial communications solutions.

Quest Technical Solutions
4110 Mourning Dove Court
Melbourne FL 32934

Phone: 321 757-8483
website: www.qtsusa.com
email: sales@qtsusa.com

